



M 250

M 250, the attention given to the study of shapes and the exclusive line design. The aesthetic and functional harmony in a great technological project.

A solid crane, equipped with advanced technologies, top quality materials and components, to obtain the best overall performance. Built for indoor and outdoor use in limited spaces and hardly accessible buildings.

The dimensions and lightweight, combined to millimetric precision manoeuvrability, allow quick and less invasive operations.

Functionality:

- Continuous boom rotation (as well with jib)
- Boom free from ballast
- Winch rope always ready, as well with Jib
- Extension cylinders inside the jib
- Jib always ready to use
- Various positions outriggers and high stroke to stabilize on every ground
- Possibility to narrow the chassis up to 780mm
- Double speed chassis
- Simple to transport, as well with a light trailer, due to the reduced weight.

Power:

- 1250kg load capacity at 10,40 mt. height, with boom in vertical position
- 650 load capacity at 15,90 mt. height, with boom and jib in vertical position

TECHNOLOGIES:

Electric Engine Always Allowed: 2,2 kW Mono Phases Electric Engine, 230V Inverter controlled.

Electronic Control System: The integrated control system give to the crane the capabilities of automatically upgrading the load limiting device to the situation determined by the position of each outriggers; permitting the operator to completely work in safety conditions.

No Limits: Easy to operate, around and over obstacles, thanks to the "ballast free" boom.

Jib Over Line: +15° Jib to overtake beyond obstacles.

Jib Ready to Use: Always "Ready to operate" folded hydraulic jib under the main boom.

Die M250, ein Studie im esclusivem Design in der Form und Linie, ein technologisches Projekt der Estetik, Harmonie, Form und Funktion I.

Kompaktkran ausgestattet mit innovativer Technologie, Komponenten bester Qualität, als Grundsatz bester Performance.

Konstruiert für hohe Anforderungen im internen und externen Bereich, bei geringen Platzbedarf, dank der Dimension und einsparendem Gewicht, sowie exakter Beweglichkeit bis auf dem Millimetergenau, sorgen für schnellen und erfolgreichen Einsatz.

Bedienbarkeit:

- Kontinuierliche Armrotation (auch mit Jib)
- Ballastfreier Arm
- Immer bewaffnetes Schleppwinde Kabel, auch mit Jib installiert
- Ausleger-Zylinder innerhalb des Jib
- Jib einsatzbereit
- Stabilisatoren mit verschiedenen Winkeln und großartiger Exkursion um auf jedem Gelände stabilisieren zu können
- Schrumpfbarer Raupenwagen bis 780 mm
- Doppelgeschwindigkeitswagen
- Transportfähig mit leichtem Trolley Dank seines geringen Eigengewicht.

Leistung:

- 1250 kg Last zu einer Höhe von 10,40 m, mit vertikalem Arm
- 650 Kg Last zu einer Höhe von 15,90 m, mit vertikalem Arm und Jib

TECHNOLOGIEN:

Elektromotor Immer Erlaubt: 2,2 kW/230V Einphasen-Elektromotor mit Inverter.

Elektronisches Steuerungssystem: Das integrierte Steuerungssystem ermöglicht dem Kran, den Lastbegrenzer automatisch auf die Situation einzustellen, die durch die Position jedes Stabilisators bestimmt wird. Dies erlaubt dem Bediener immer in Sicherheit Konditionen zu arbeiten.

Keine Grenzen:

Endlose Drehung ohne Raumbedarf Dank dem Belastfreier Arm.

Jib über Leitung: Jib bei + 15 °, um Hindernisse zu überwinden.

Jib Einsatzbereit

Jib geschlossen unter dem Haupt Arm immer betriebsbereit.

BG LIFT, divisione "Gru compatte" di Brennero Gru, solida realtà produttiva nel settore del sollevamento. **BG LIFT** è un brand leader estremamente propositivo e fortemente focalizzato verso l'innovazione tecnologica e il design distintivo.

BG LIFT, A Brennero Gru "Compact Crane" Division, solid Production Reality of the Lifting Branch. **BG LIFT** is a leader Brand, Extremely Positive, ambitious and deeply focused on technologic innovation and Peculiar Design.

BG LIFT, Abteilung für "kompakte Kräne" von Brennero Gru, solide Produktgesellschaft im Kran - Sektor. **BG LIFT**, ist ein Leader-Brand und extrem Ausschau-haltend für Innovation in der Technologie und Design.



DB0002_0-IT-EN-DE

M 250

Bg Lift S.r.l
Via Lionello Fiumi, 22
37010 Cavaion Veronese (VR) Italy
Phone: +39 045 8240360
e-mail: info@bglift.com

www.bglift.com



M 250 Li-ion
LITHIUM
BATTERY
AVAILABLE



M 250

GRU CINGOLATA COMPATTA
COMPACT CRAWLER CRANE
KOMPAKTKRAN AUF ROLLSCHIENEN

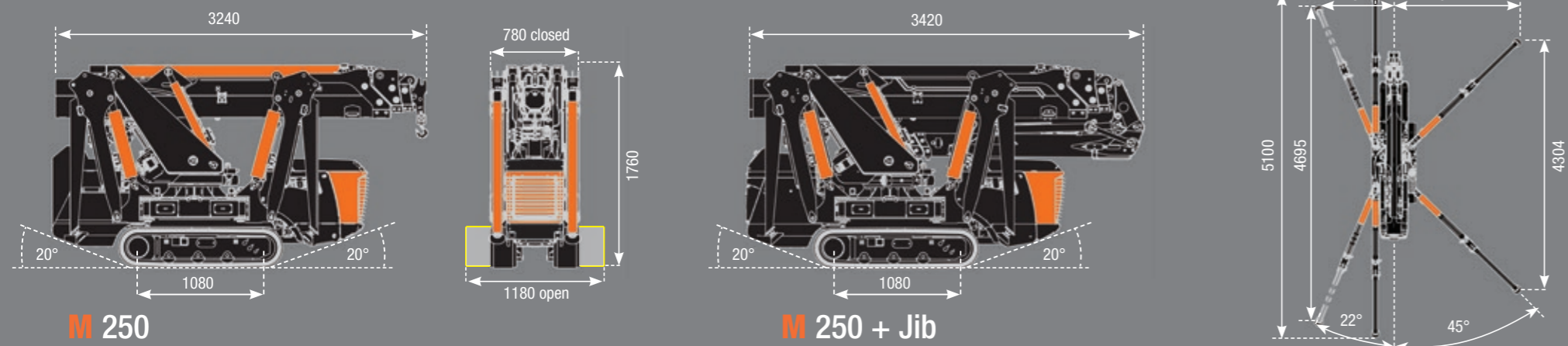

SPECIFICHE TECNICHE / TECHNICAL SPECIFICATIONS / TECHNISCHE MERKMALE

	Carico massimo gru Max capacity Traglast	2500 Kg / 1,5 m
	Raggio massimo di lavoro Max outreach Maximaler Arbeitsradius	8,43 m
	Raggio massimo di lavoro con Jib idraulico (optional) Max outreach with Jib (optional) Maximaler Arbeitsradius mit hydraulischem Jib (optional)	12,85 m
	Altezza massima del braccio Max hook height Maximale Höhe des Armes	10,40 m
	Altezza massima con Jib idraulico (optional) Max hook height with Jib (optional) Maximale Höhe des Armes mit hydraulischem Jib (optional)	15,90 m
	Angolo di rotazione-Velocità Slewing angle-speed Schwenkbereich - Fahrgeschwindigkeit	Continua / 1,5 rpm Continuous / 1,5 rpm Endlos / 1,5 rpm
	Argano (optional) Winch (optional) Seilwinde (optional)	Tiro in diretta / First layer pull / Traglast 1-strangig Lunghezza fune / Rope lenght / Seillänge Velocità in tiro diretto / Speed in direct pull / Geschwindigkeit bei 1-Strang-Betrieb
	Radiocomando Radio remote control Fernsteuerung	Scanreco Can-Bus + Display
	Limitatore di carico Stability control Lastmomentbegrenzer	Elettronico Electronic Computergesteuert

	Stabilizzazione Stability system Abstützung	24 posizioni 24 different position 24 verschiedene Position	Max 4155x4300
	Peso degli elementi Weights Gewichte	Gru standard / Standard crane / Standard krane Jib Motore elettrico / Electric motor / Electromotor Argano / Winch / Seilwinde	2420 Kg 210 Kg 40 Kg 65 Kg
	Trazione carro cingolato Crawler Crane Traction Antrieb des Raupenkrans	Trasmissione / Transmission / Antrieb Portata / Scope / Zulässige Traglast Pressione / Pressure / Druck Velocità / Speed / Fahrgeschwindigkeit Pendenza max / Max slope degree / Max. überwindbare Steigung Pressione al suolo / Max pressure on the ground / Bodendruck	Riduttore Epicicloidale / Moto-reducer/ Planetengetriebe 50 l/min 170 bar 0 - 2 Km / h 25° 0,47 Kg / cm ²
	Motore diesel Diesel Engine Diesel Motor	Marca / Brand / Marke Modello / Model / Typ Potenza max / Max power / Max Leistung Coppia max / Max torque / Maximale Drehmoment Capacità serbatoio / Tank capacity / Tankinhalt	Yanmar 3TNV70 16.3 kW / 22.2 Hp 48 Nm 13 l

OPTIONAL

- Argano idraulico da 900 Kg
- Ganci Ribassati
- Carrucole per tiro triplo
- Fari di lavoro a LED per gru e Jib
- Jib idraulico con operatività di 195°
- Motore elettrico monofase 2,2 Kw/230 V con inverter
- Acceleratore dei giri motore automatico
- Cingoli antiraccia
- Cestelli porta operatore CE
- Piastre maggiorate per stabilizzatori
- Olio Idraulico biodegradabile
- Auto chiusura.
- 900 Kg hydraulic winch
- Lowered hook connections
- Third line pull pulleys
- Working LED lights on the boom and Jib
- Hydraulic Jib with opening up to 195°
- Mono phase electric engine 2,2 kW/230 V with inverter
- Automatic engine rpm increment
- No marking rubber pads
- Two man capacity baskets CE
- Plates for outriggers
- Green oil
- Automatic closing.
- Hydraulische Seilwinde Traglast max. 900 Kg
- Niedrige Last-Haken
- Seilrolle mit 3-fach Seilzug
- Arbeitsscheinwerfer am Arm und Jib
- Hydraulischer Jib mit 195° Knickradius
- 2,2 kW 230V Einphasen-Elektromotor mit Inverter
- Automatisches Gaspedal
- Spurlos Gummiketten
- Arbeitskorb für Personen CE
- Groessere Plattformen für Stabilisatoren
- Biologisch Hydrauliköl
- Automatisches Schließen.

DOTAZIONI STANDARD / STANDARD EQUIPMENT / SERIENAUSSTATTUNG

- Radiocomando con display per ogni funzione del carro, stabilizzatori e gru
- Rotazione continua
- Predisposizione per argano
- Predisposizione per il Jib
- Stabilizzazione a più posizioni
- Stabilizzazione Automatica
- Avanzamento cingolo a 2 velocità
- Carro allargabile
- Acceleratore dei giri motore manuale
- N° 2 fari di lavoro a LED sul carro
- N° 4 attacchi per il sollevamento
- Limitatore di carico elettronico
- Autodiagnosi
- Gru colore nero RAL 9005
- Cilindri colore arancio
- Normativa di riferimento EN13000.
- BG Connect.
- Radio remote control with display for crawler, chassis and crane function.
- Continuous rotation
- Predisposition for winch Installation
- Predisposition for Jib Installation
- Outrigger with different stability position
- Automatic stabilization
- Two Speed Crawler Translation
- Extendable Crawler
- N° 2 working LED lamps on the crawler
- Engine manual Rpm increment
- N° 4 Lifting Connections
- Electronic Limiting Device
- Auto diagnostic
- Crane Color Black RAL 9005
- Cylinders color orange
- According To EN13000
- BG Connect.
- Fernbedienung mit Display für alle Funktionen des Rahmens (Fahrwerk), Stabilisatoren und Kran
- Endlos Umdrehung
- Vorbereitung für Winde
- Vorbereitung für JIB
- Multi-Positionen- Abstützung
- Automatische Abstützung
- Zweistufige Geschwindigkeit der Fahrwerk
- Ausziehbarer Wagen
- Manuelle Beschleuniger für Gaspedal
- N°2 Ledlicht am Fahrwerk
- N°4 Festpunkte für das Heben der Fahrwerk
- Elektronische Lasthaltventil
- Auto-Diagnose
- Farbe des Krans Schwarz RAL 9005
- Farbe der Zylinder Orange
- Übereinstimmung mit der Norm EN 13000
- BG Connect.

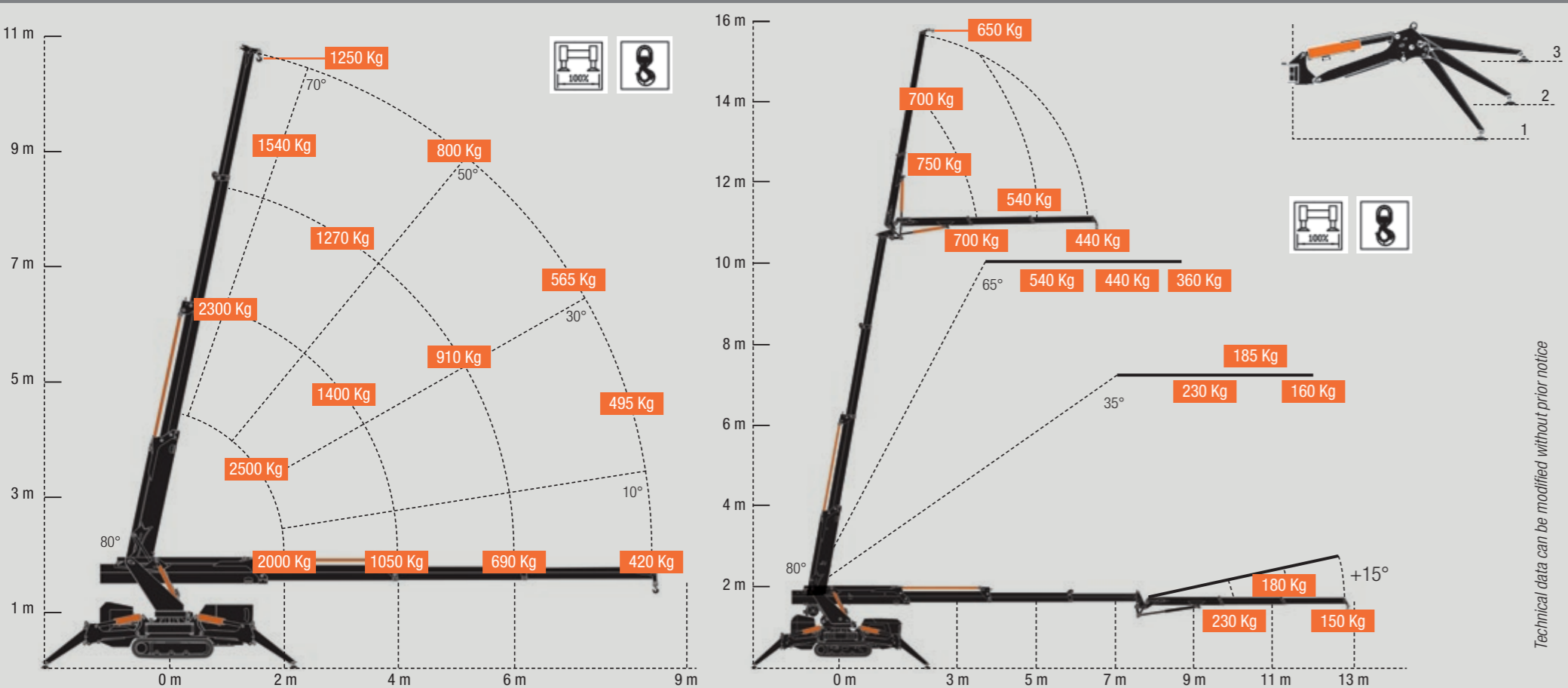

Technical data can be modified without prior notice

M 250, lo studio delle forme e il design esclusivo delle linee. L'armonia estetico-funzionale di un grande progetto tecnologico. Gru compatta, equipaggiata con tecnologie innovative, componenti e materiali di qualità, per ottenere le migliori performance. Progettata sia per utilizzo interno, che esterno. Ideale per operare in accessi difficili e spazi limitati. Le dimensioni e il peso contenuti, unite ad una manovrabilità con precisione millimetrica, consentono lavori rapidi, veloci e meno invasivi.

- Operatività:**
- Rotazione continua del braccio (anche con Jib)
 - Braccio libero da zavorra
 - Fune del verricello sempre armata, anche con Jib installato
 - Cilindri di sfilo interni al Jib
 - Jib sempre pronto all'uso
 - Stabilizzatori con varie angolature e grande escursione per ogni terreno
 - Carro cingolato restringibile fino a 780 mm
 - Carro con doppia velocità
 - Trasportabile con carrello leggero grazie al peso ridotto.

Potenza:
- 1250 Kg di portata ad h 10,40 m, con braccio verticale
- 650 Kg di portata ad h 15,90 m, con braccio e Jib verticale

TECNOLOGIE:

Motore Elettrico Sempre Operativo:
Motore elettrico Monofase 2,2 kW con inverter 230 V.

Sistema di Controllo Elettronico:
Il Sistema di controllo integrato consente alla gru di adeguare automaticamente il limitatore di carico alla situazione determinata dalla posizione di ogni stabilizzatore. Sicurezza totale per l'operatore.

Nessun Limite:
Rotazione infinita senza ingombri grazie al braccio libero da zavorre.

Jib Sopra l'Orizzontale: Jib a +15°, per scavalcare gli ostacoli.

Jib Pronto all'Uso:
Completamente ripiegabile idraulicamente sotto il braccio principale.

M 250 Li-ion
Alimentata da Batteria al Litio / Powered by Lithium Battery
Angetrieben durch Lithium-Batterie



Technical data can be modified without prior notice